

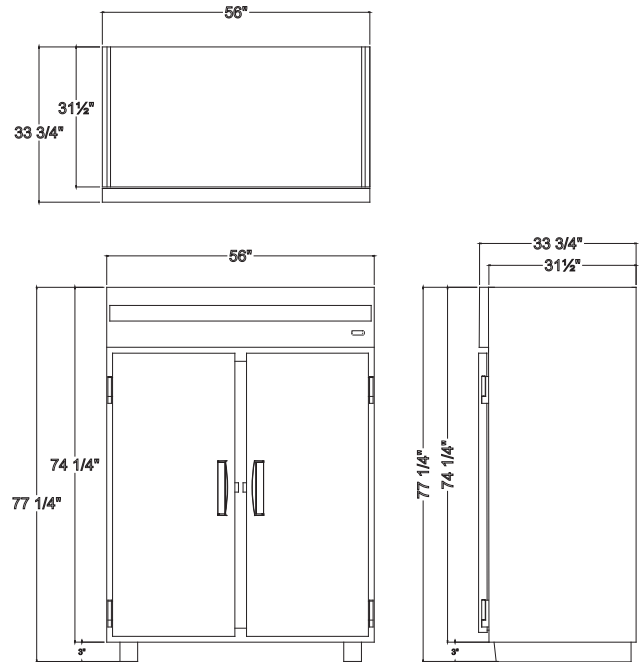

## PRODUCT



## TECHNICAL VIEWS



## STANDARD FEATURES

- Electronic control with energy saving function
- Environmentally Friendly R290 Refrigerant
- Foamed-in-placed high density polyurethane insulation: provides a solid structure and low energy consumption
- LED lightning

## OPTIONAL FEATURES

- Swivel casters 6"
- Voltage 220v/60Hz-50Hz
- Smart Control IoT
- Electric Condensate Evaporator Tray
- Voltage regulator

## TECHNICAL SPECS

<i>Internal Capacity</i>	<i>Ft<sup>3</sup></i> 48	<i>Liters</i> 1359.21	
<i>Exterior Dimensions</i>	<i>Width</i> 56.00" 1422.40 mm	<i>Depth</i> 33.75" 857.25 mm	<i>Height</i> 77.25" 1962.15 mm
<i>Container Capacity</i>	<i>40 ft</i> 16	<i>45 ft</i> 18	
<i>Temperature Range</i>	<i>°C</i> -23°C   -17°C	<i>°F</i> -10°F   0°F	
<i>Shelves</i>	<i>6</i>		
<i>Weight Approx.</i>	<i>188 kg.</i>		
<i>Compressor HP</i>	<i>n/d</i>		
<i>Amperage</i>	<i>n/d</i>		
<i>Voltage/Frequency</i>	<i>115v / 60hz</i>	<i>Plug</i>	<i>NEMA 5-15P</i>
<i>Drain Type</i>	<i>Requires connection to a drain</i>		